

Series 820 Top-Trak

mass flowmeters

4



Description	How It Works															
<p>Thermal mass flowmeters like the Series 820 Top-Trak are more reliable than volumetric flow devices like rotameters because they are relatively immune to changes in gas temperature and pressure. Because these instruments measure molecular flow, they provide the most reliable and accurate method of delivering gas to your system.</p> <p>The 820 is designed to measure the flow of non-corrosive gases. The instruments built-in display, power supply, and readout electronics, provides an easy and convenient method of accurately monitoring the gas flow of your system. A straight, large diameter sensor tube prevents clogging and contamination.</p> <p>Available in flow ranges from 0-10 sccm to 0-40 slpm. The standard unit can be supplied with either 0-5 VDC or 4-20 mA output signals.</p>	<p>Gas enters the Top-Trak and divides into two flow paths. Most of the flow goes through the laminar flow by-pass. This creates a pressure drop that forces a known fraction of the flow through the sensor tube. Two resistance temperature detector coils around the sensor tube direct a constant amount of heat into the gas stream. Heat transfer between these elements results in the interaction with the molecules of the flowing gas, independent of temperature and pressure fluctuations. The sensor signal is amplified, linearized and calibrated to achieve a direct reading of gas mass flow rate.</p>															
Materials	Specifications															
<p><i>Wetted materials are</i></p> <ul style="list-style-type: none"> 10% glass-filled nylon 6/6 316 stainless steel nickel plating Viton o-rings 	<p><i>Accuracy</i> ± ± 1.5% of full scale</p> <p><i>Repeatability</i> ± 0.5% of full scale</p> <p><i>Gas and ambient temperature</i> 32 to 120°F</p> <p><i>Gas pressure</i> 20 psig optimum, 150 psig max.</p> <p><i>Leak integrity</i> 1 x 10⁻⁴ ATM cc/sec of helium</p> <p><i>Input power</i> 12-18 VDC</p> <p><i>Output signal</i> linear 0-5 VDC standard 4-20 mA optional</p>	<p><i>Response time</i> 800 ms time constant</p> <p><i>Pressure Coefficient</i> 0.02% of full scale per psi (0.07 kg/cm²) or better</p> <p><i>Pressure drop</i></p> <table border="1" data-bbox="1218 1617 1477 1827"> <thead> <tr> <th>Flow Rate</th> <th>Max ΔP</th> </tr> </thead> <tbody> <tr> <td>SLM</td> <td>cm of</td> </tr> <tr> <td>water</td> <td></td> </tr> <tr> <td>up to 10</td> <td>7</td> </tr> <tr> <td>20</td> <td>25</td> </tr> <tr> <td>30</td> <td>47</td> </tr> <tr> <td>40</td> <td>88</td> </tr> </tbody> </table> <p><i>Temperature coefficient</i> 0.15% of full scale per °C or better</p>	Flow Rate	Max ΔP	SLM	cm of	water		up to 10	7	20	25	30	47	40	88
Flow Rate	Max ΔP															
SLM	cm of															
water																
up to 10	7															
20	25															
30	47															
40	88															

mass flowmeters **Series 820 Top-TraK**

4

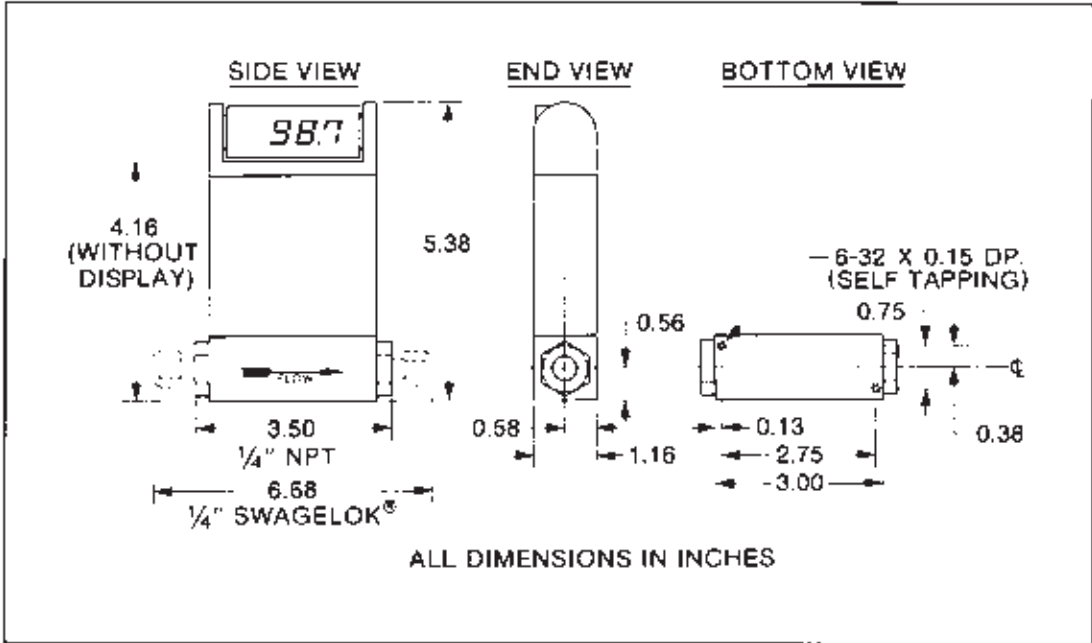

Series 820 Dimensional Drawing

Ordering Information	
822-W-X-Y-Z (Select X, Y, and Z parameters from table below)	
W = Inlet and outlet connections:	P4FF = 1/4" NPT female T2FF = 1/8" compression fittings (up to 15 slpm) T4FF = 1/4" compression fittings
X = inlet and outlet pressure calibration:	NF = normal pressure (up to 40 psig) MP = 40-150 psig
Y = flow range:	0-10 sccm = 00010 0-20 sccm = 00020 0-50 sccm = 00050 0-100 sccm = 00100 0-500 sccm = 00500 0-1 slpm = 01000 0-2 slpm = 02000 0-5 slpm = 05000 0-10 slpm = 10000 0-20 slpm = 20000 0-30 slpm = 30000 0-40 slpm = 40000 0-50 slpm = 50000
Z = factory set output option:	V = 0-5 VDC A = 4-20 mA

All flows are based on standard conditions of 70°F and 1 ATM unless otherwise specified when ordering.